

The information in this document is subject to change without notice and should not be construed as a commitment by ABB. ABB assumes no responsibility for any errors that may appear in this document.

Except as may be expressly stated anywhere in this document, nothing herein shall be construed as any kind of guarantee or warranty by ABB for losses, damages to persons or property, fitness for a specific purpose or the like.

In no event shall ABB be liable for incidental or consequential damages arising from use of this document.

This document and parts thereof must not be reproduced or copied without ABB's written permission, and contents thereof must not be imparted to a third party nor be used for any unauthorized purpose. Contravention will be prosecuted.

Additional copies of this document may be obtained from ABB at its then current charge.

©Copyright 2007 ABB ALL right reserved.

ABB Automation Technologies AB
 Robotics
 SE-721 68 Västerås
 Sweden

We reserve all rights in this document and in the information contained therein. Reproduction, use or disclosure to third parties without express authority is strictly forbidden. © Copyright 2003 ABB

Latest revision:	Prepared by, date: CNHACHE26	Approved by, date: Chao Xie		Lab/Office:	COPYRIGHT page	Status: 10/14/2020	Plant: = IRB1600
						Approved	Location: +
Document no. 3HAC021351-003						Rev. Ind 06	Page 1
							Next 2
							Total 17

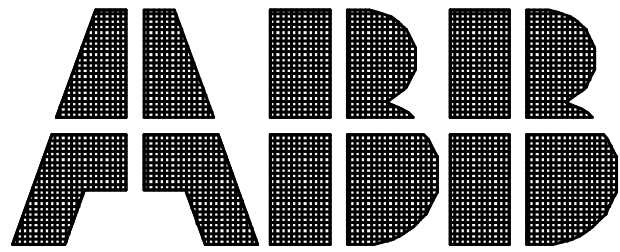

Customer :
 Robot serial number(s) :
 Drawing number : 3HAC021351-003
 Drawing version :

Manufacture : 10/14/2020
 Type :
 Type of installation :
 Control cabinet :
 Mains voltage :
 Supply :
 Control voltage :
 Year of construction :

Project start :
 Project manager :
 Last revision :
 Designed by : CNHACHE26
 Designed date : 10/14/2020
 Number of pages : 17
 :

We reserve all rights in this document and in the information contained therein. Reproduction, use or disclosure to third parties without express authority is strictly forbidden. © Copyright 2003 ABB

We reserve all rights in this document and in the information contained therein. Reproduction, use or disclosure to third parties without express authority is strictly forbidden. © Copyright 2003 ABB

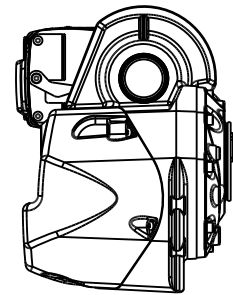

IRB 1660ID - 6/1.55
IRB 1660ID - 4/1.55

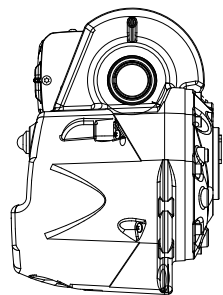

IRB 1600ID - 4/1.5

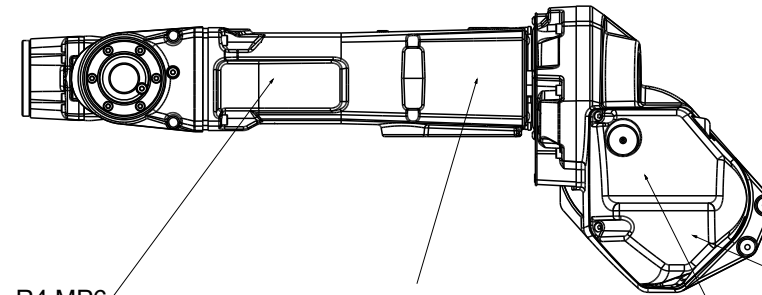
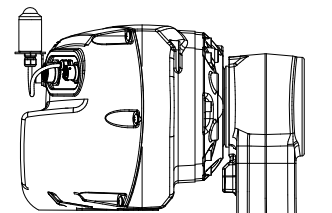

R4.MP6
R4.FB6
R4.MP5
R4.FB5
R3.FB3
R3.FB4
R3.FB5
R3.FB6
R3.MP3
R3.MP4
R3.MP5
R3.MP6
R3.H1
R3.H2

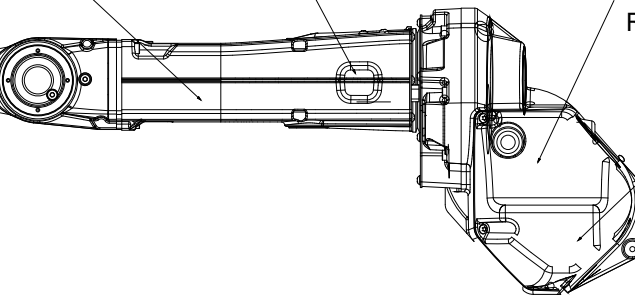

R2.CS
Air
R2.CP
R3.FB3
R3.FB4
R3.FB5
R3.FB6
R3.MP3
R3.MP4
R3.MP5
R3.MP6
R3.H1
R3.H2

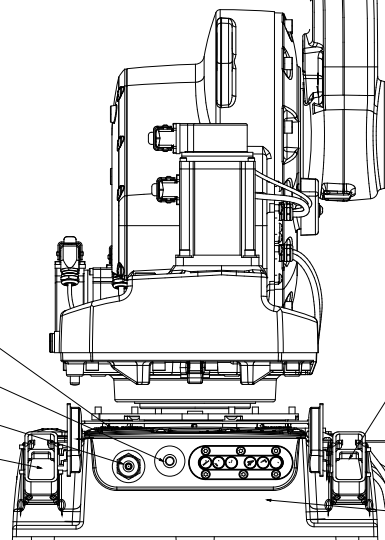

R1.SMB1.7
R2.FB7
Air
R1.SMB
R1.MP
R1.CP/CS
R1.CP
R1.CS
R1.LS
R1.FB1-2
R2.G
R1.FB3-6
R2.BU
R2.SMB
R2.BU1-6

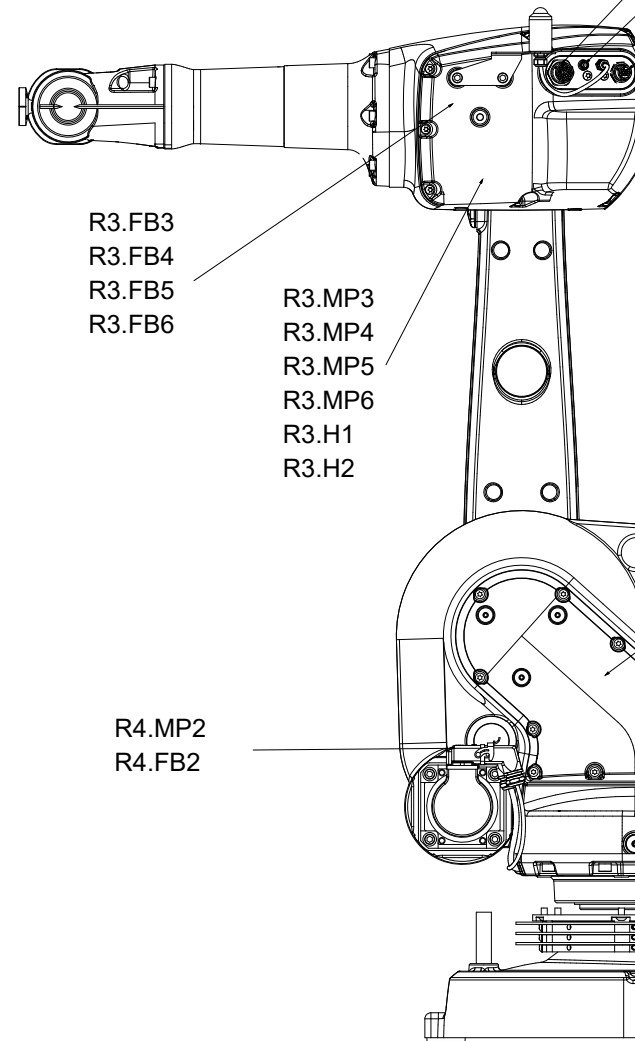

R3.FB3
R3.FB4
R3.FB5
R3.FB6
R3.MP3
R3.MP4
R3.MP5
R3.MP6
R3.H1
R3.H2
R4.MP2
R4.FB2
R3.MP1
R3.MP2
R3.FB1
R3.FB2
R4.FB1
R4.MP1

Latest revision:		ABB	Lab/Office:	Status: 10/14/2020	Plant: = IRB1600
				Manipulator Connection Points	Approved
Prepared by, date: CNHACHE26	Approved by, date: Chao Xie			Document no. 3HAC021351-003	Sublocation: +
				Rev. Ind 06	Page 11
					Next =/20
					Total 17

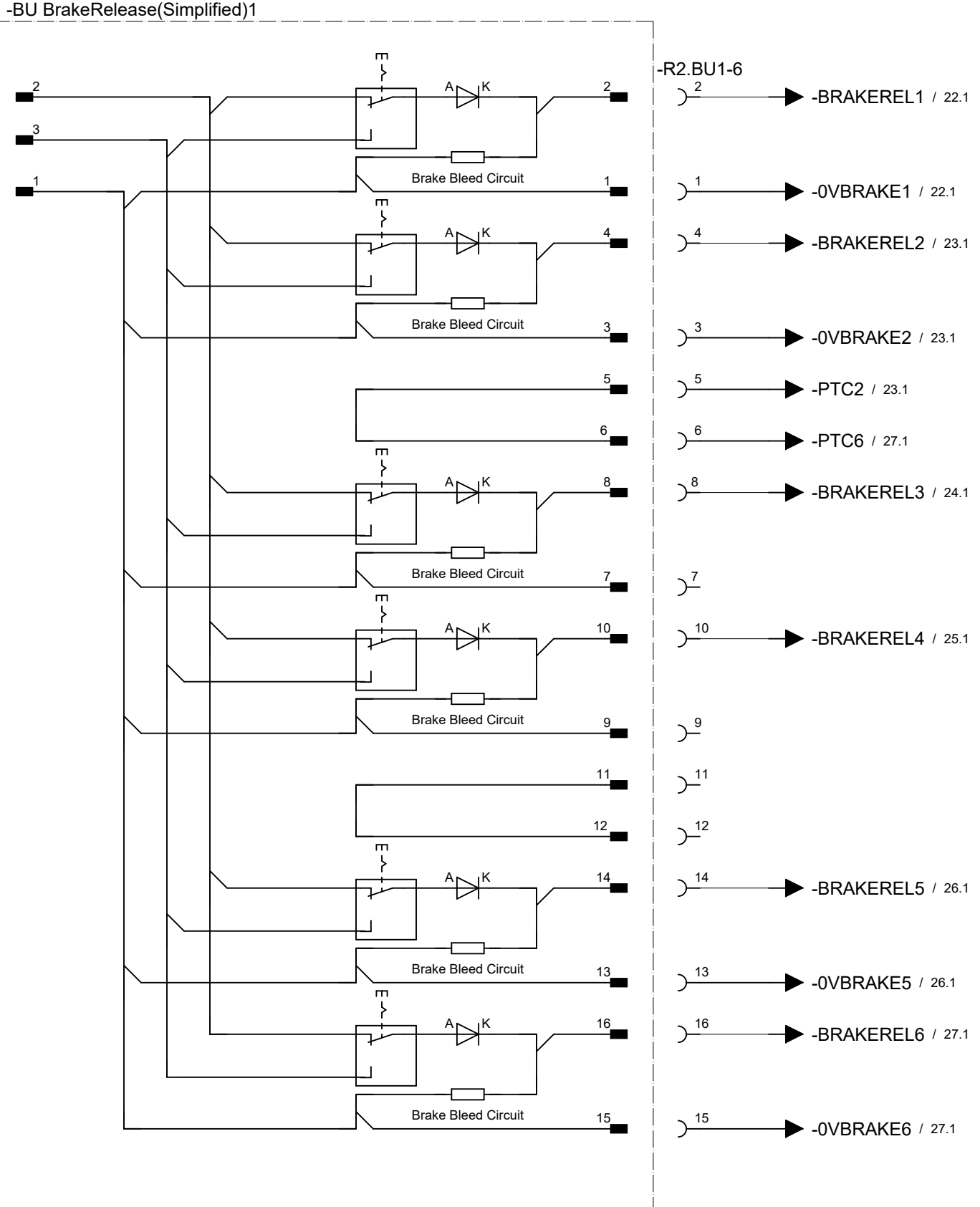
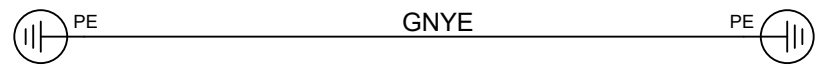

Latest revision:

Prepared by, date: CNHACHE26 Approved by, date: Chao Xie



Lab/Office: Brake Release Unit

Status: 10/14/2020	Plant: =
Approved	Location: +
	Sublocation: +
Document no. 3HAC021351-003	Rev. Ind 06
	Page 20
	Next 21
	Total 17

We reserve all rights in this document and in the information contained therein. Reproduction, use or disclosure to third parties without express authority is strictly forbidden. © Copyright 2003 ABB

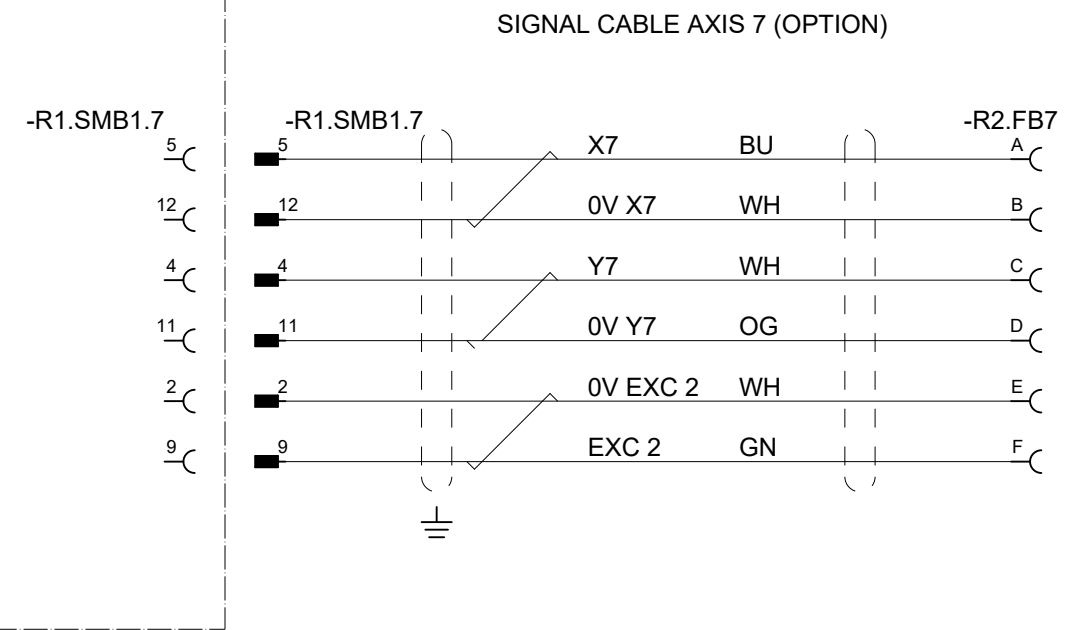
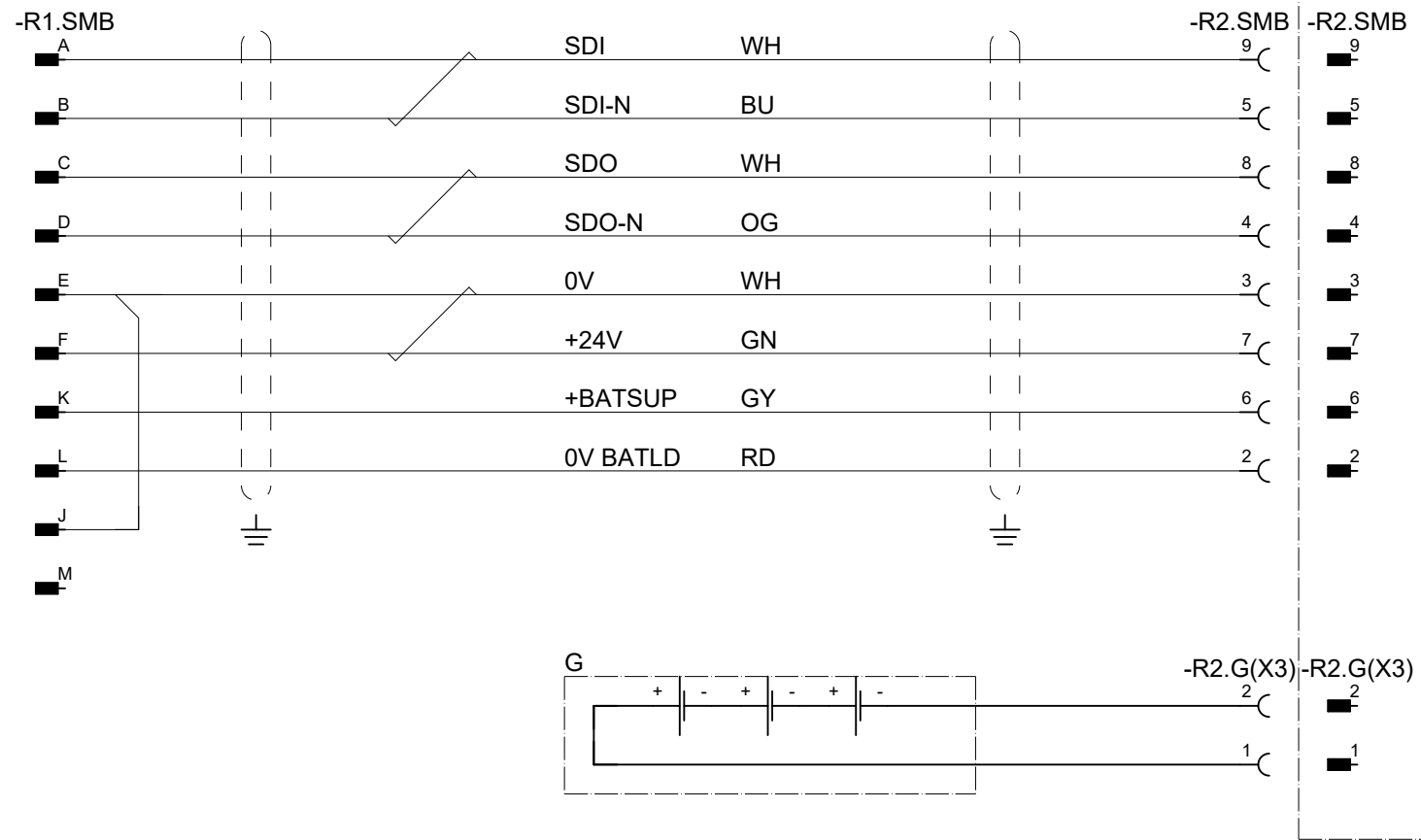

Latest revision:
 Prepared by, date: CNHACHE26 | Approved by, date: Chao Xie



Lab/Office:

Serial Measurement Board

Status: 10/14/2020	Plant: =
Approved	Location: +
	Sublocation: +
Document no. 3HAC021351-003	Rev. Ind 06
	Page 21
	Next 22
	Total 17

We reserve all rights in this document and in the information contained therein. Reproduction, use or disclosure to third parties without express authority is strictly forbidden. © Copyright 2003 ABB

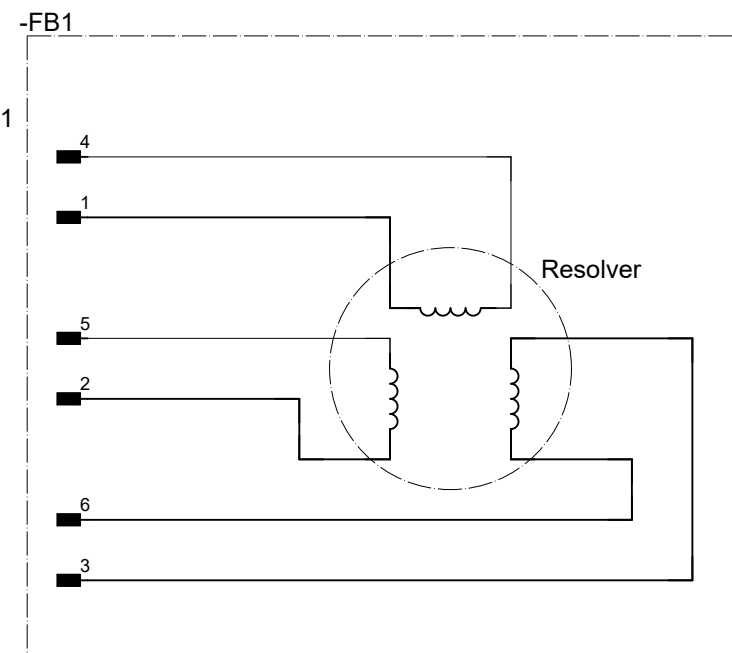
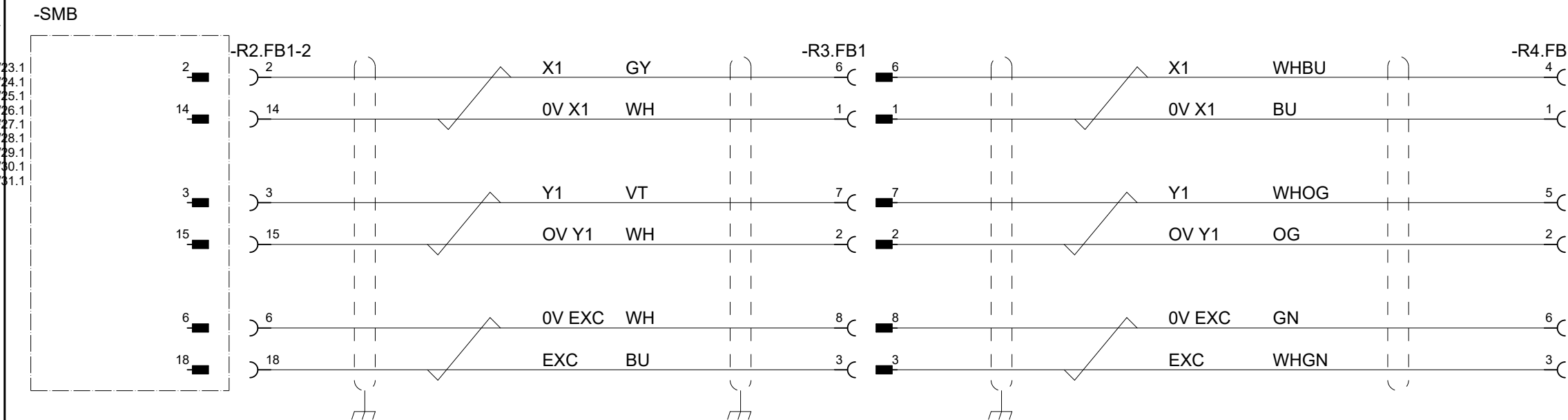
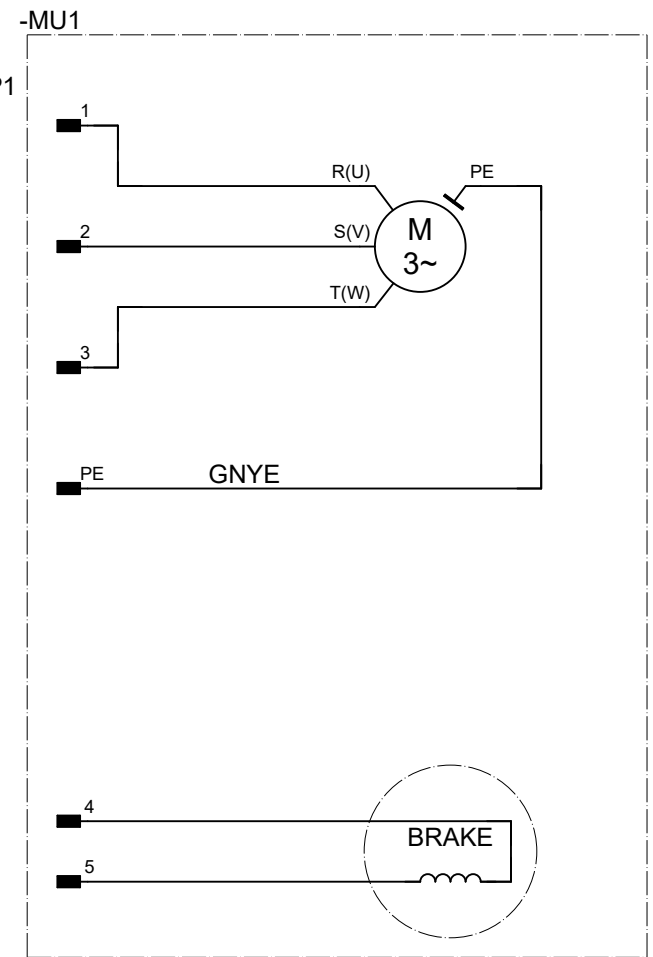
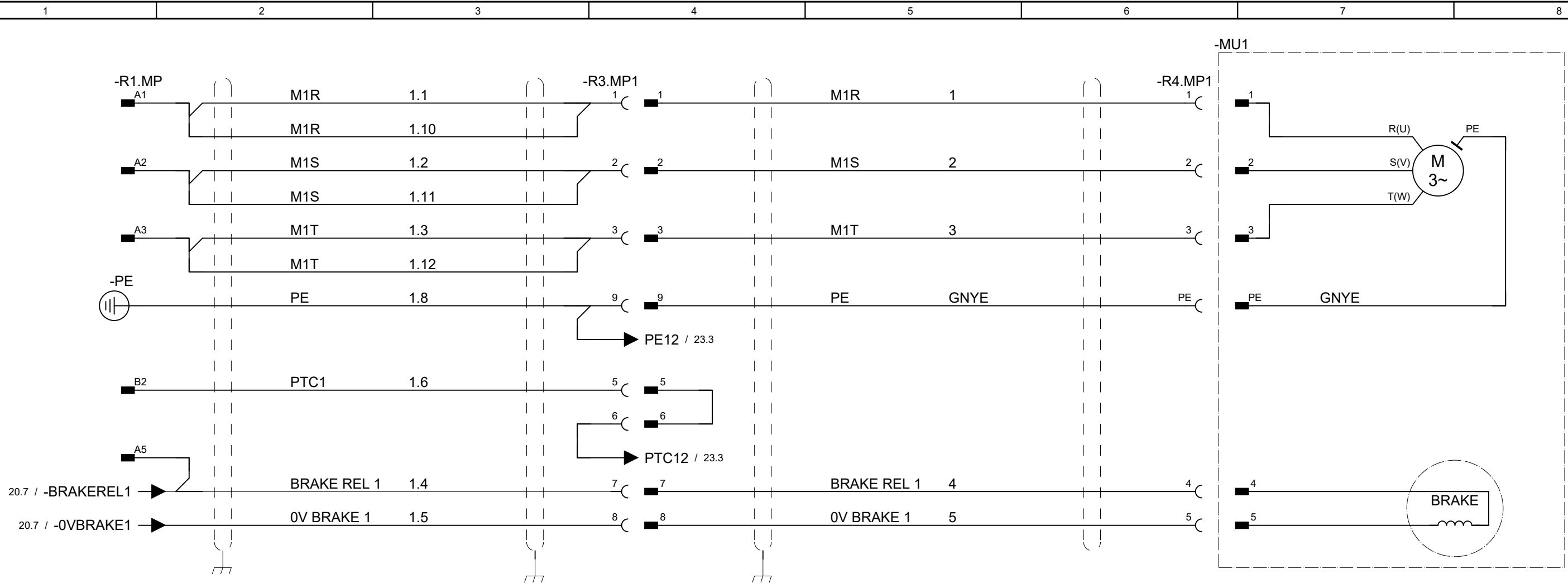

We reserve all rights in this document and in the information contained therein. Reproduction, use or disclosure to third parties without express authority is strictly forbidden. © Copyright 2003 ABB

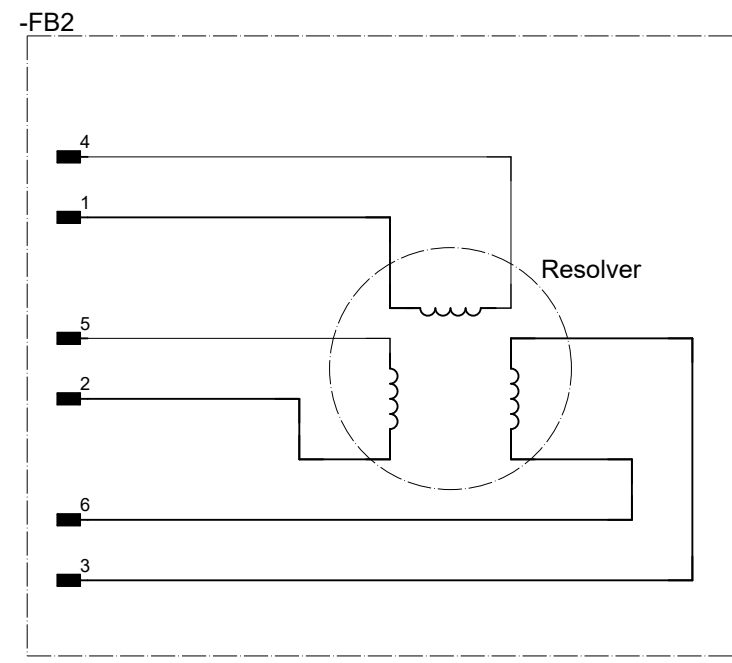
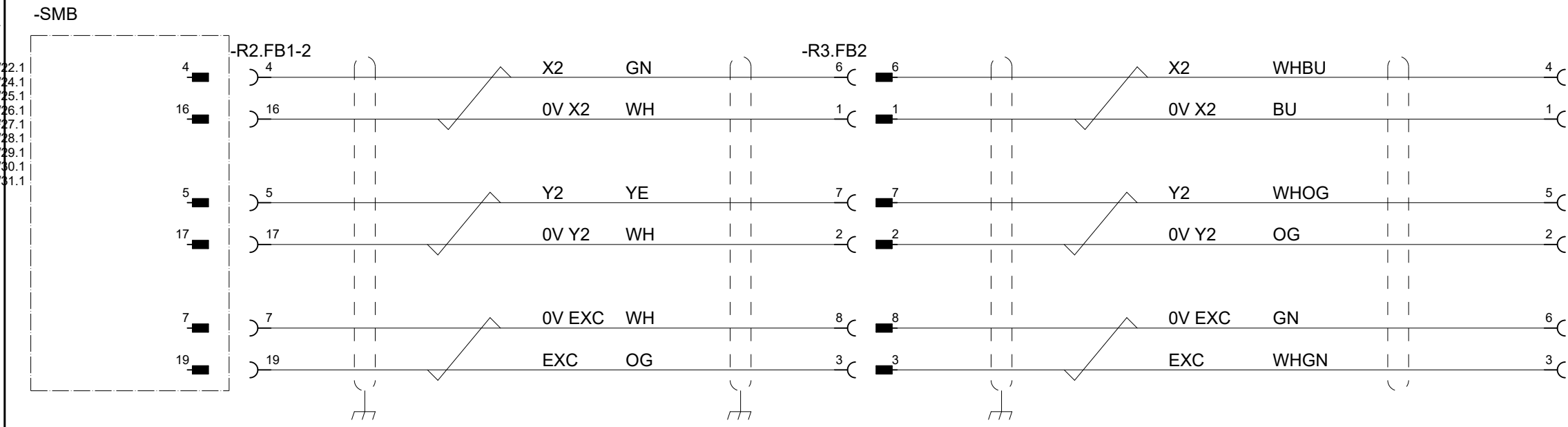
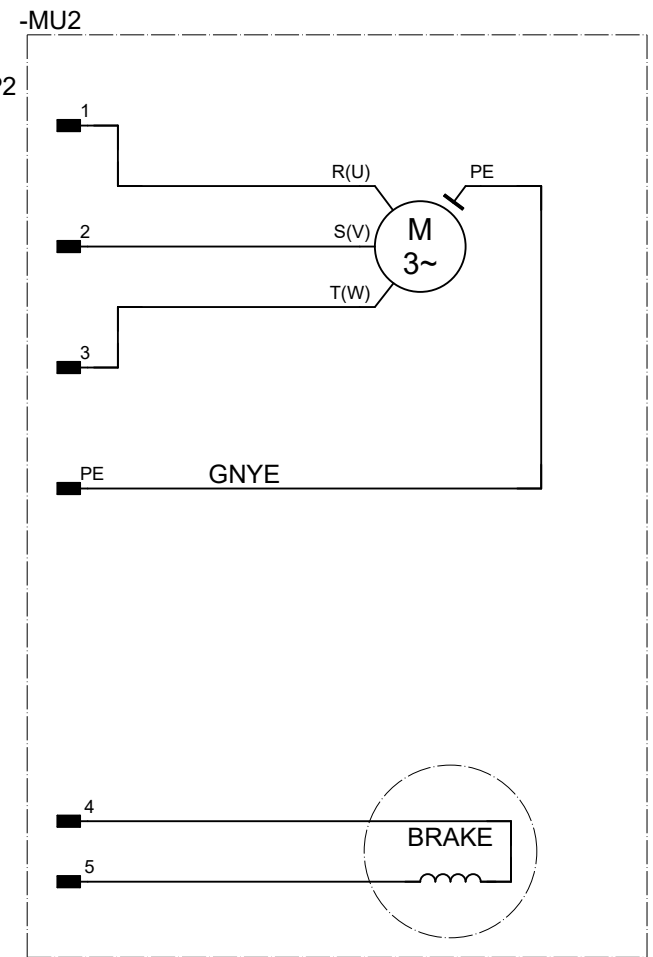
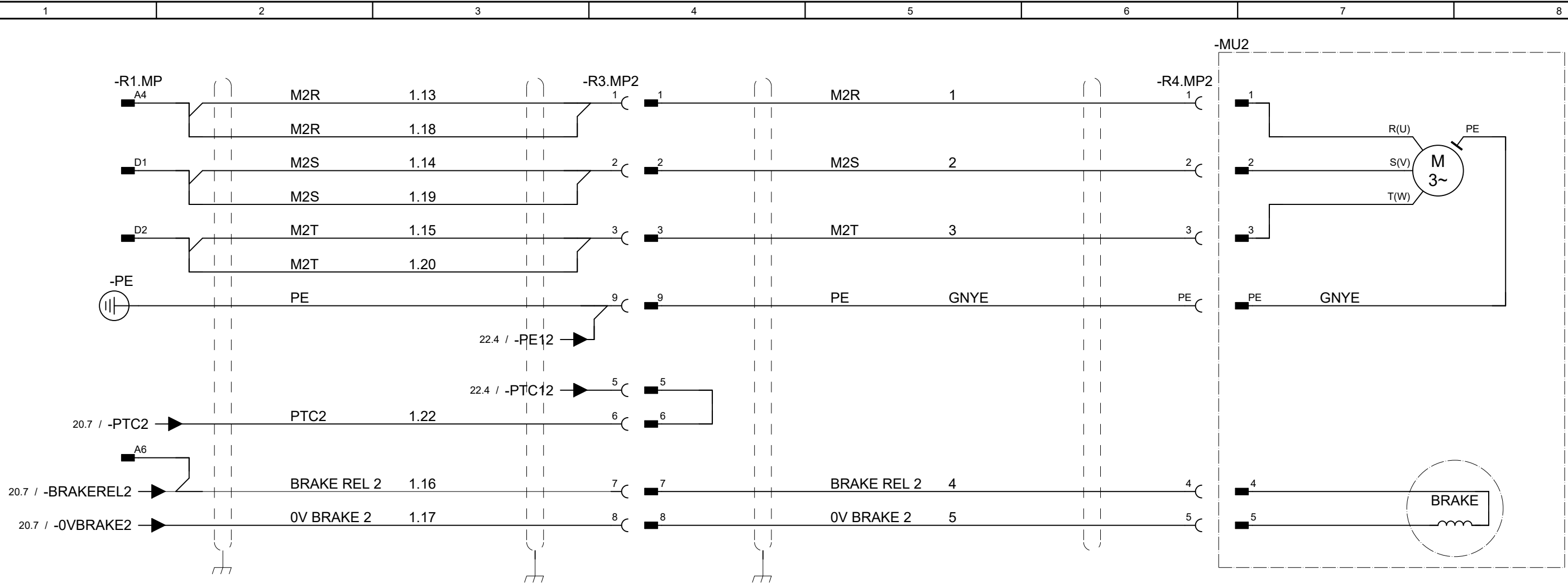

We reserve all rights in this document and in the information contained therein. Reproduction, use or disclosure to third parties without express authority is strictly forbidden. © Copyright 2003 ABB

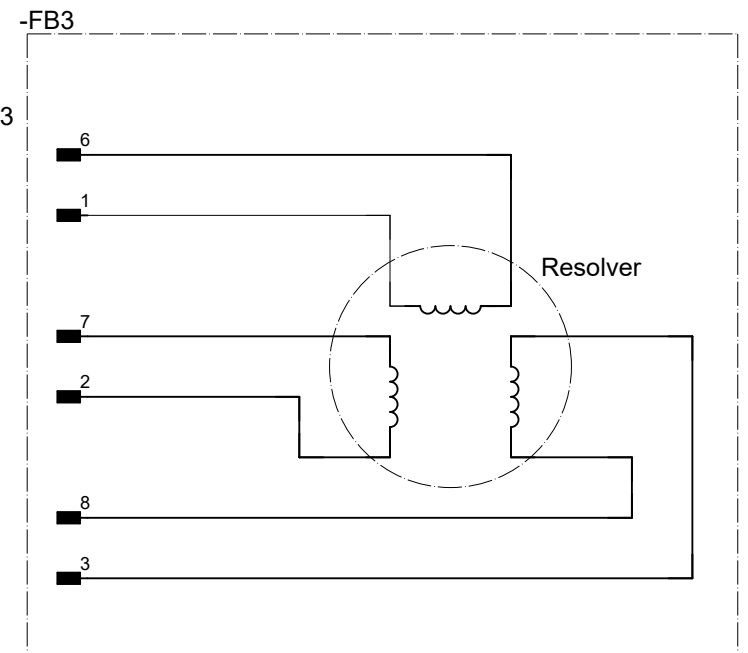
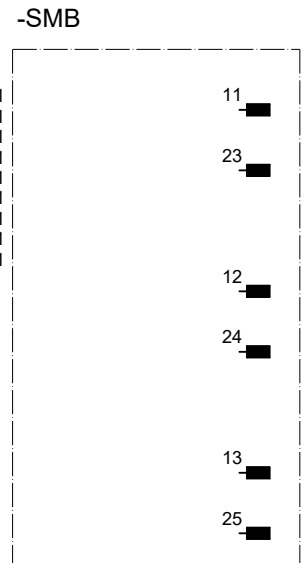
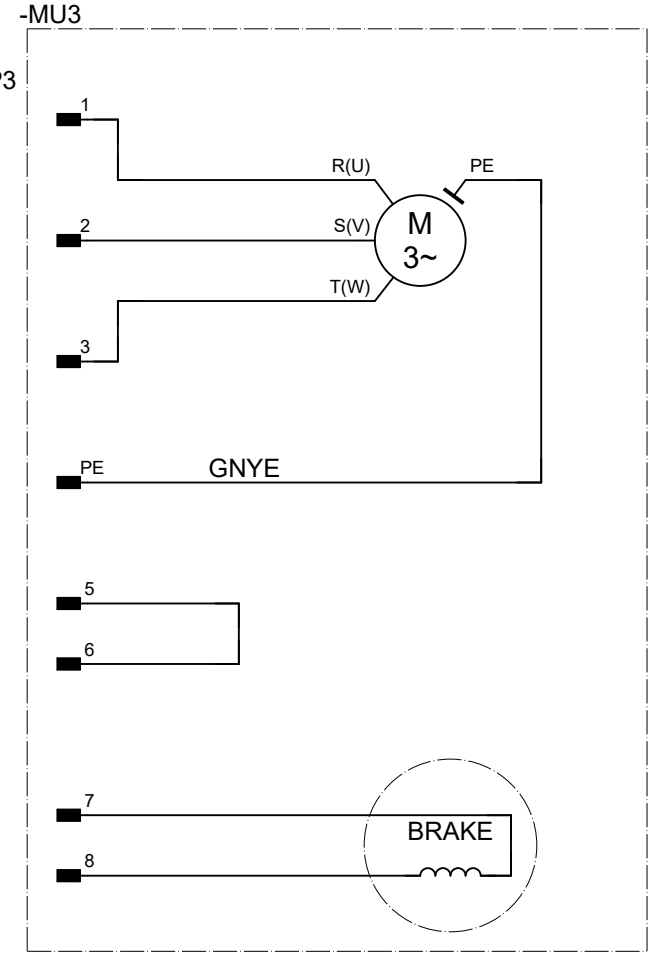
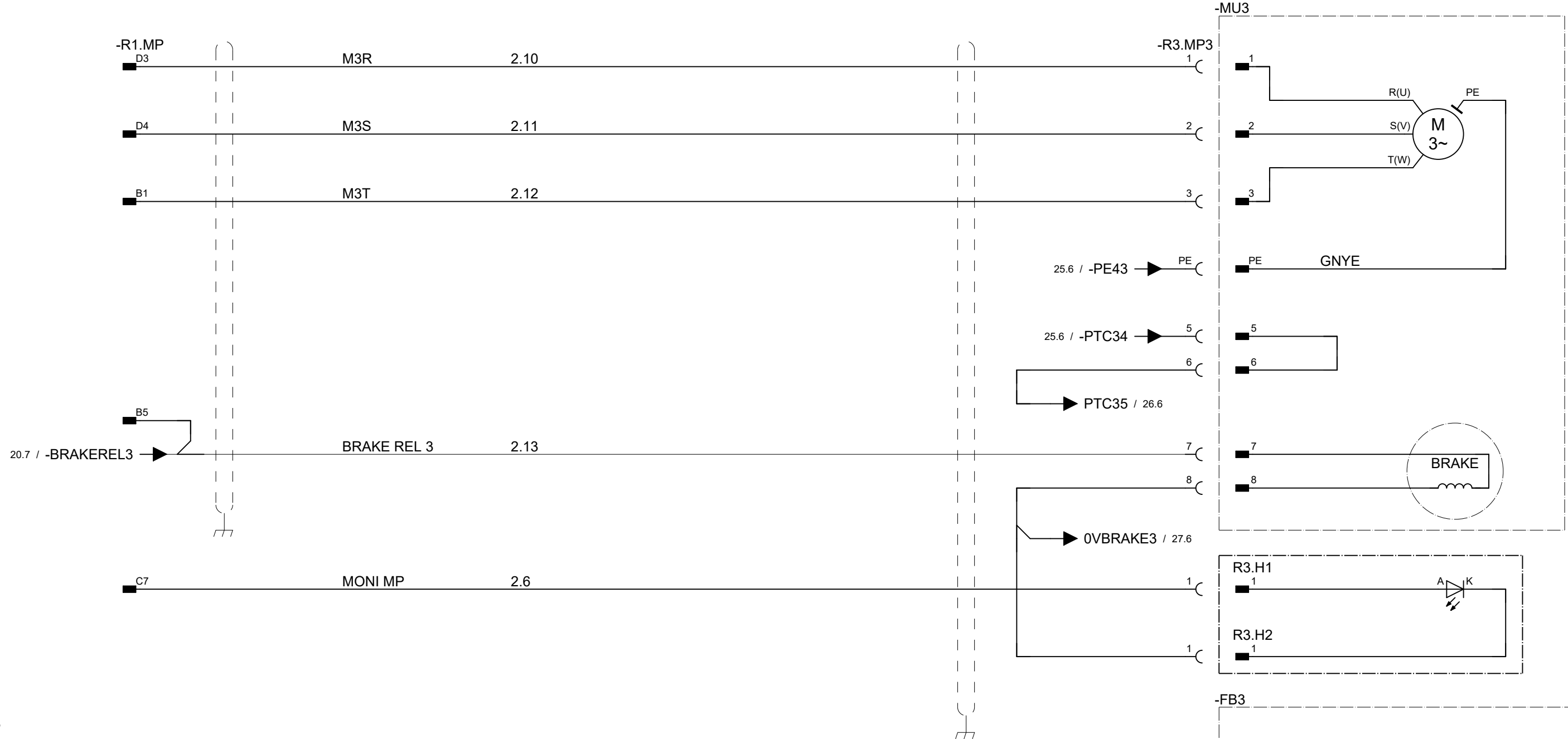

We reserve all rights in this document and in the information contained therein. Reproduction, use or disclosure to third parties without express authority is strictly forbidden. © Copyright 2003 ABB

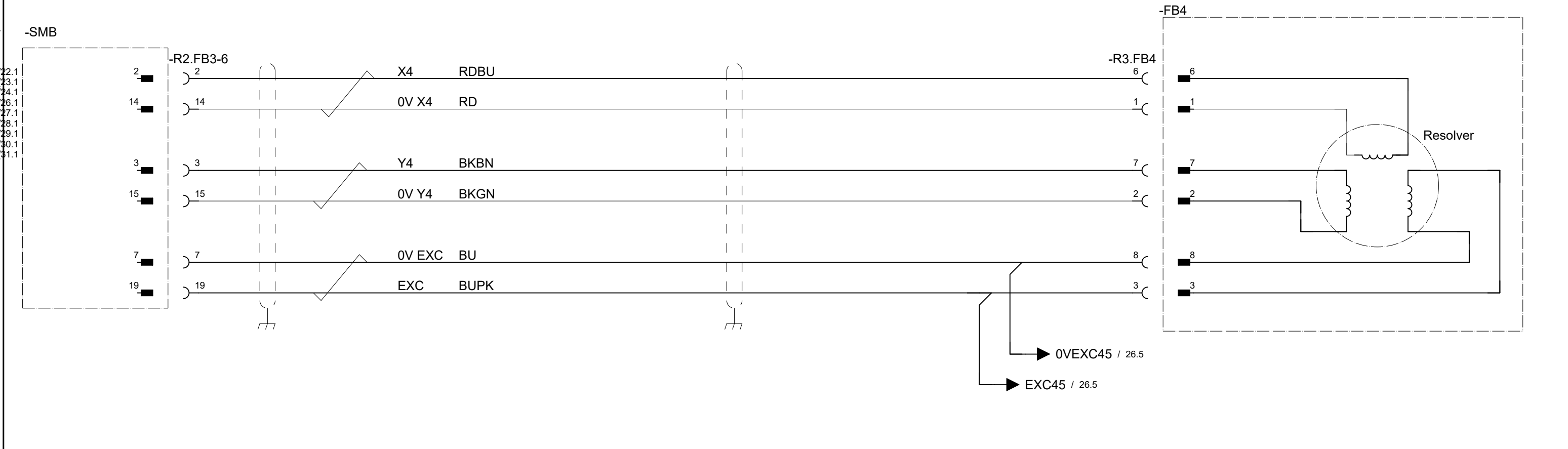
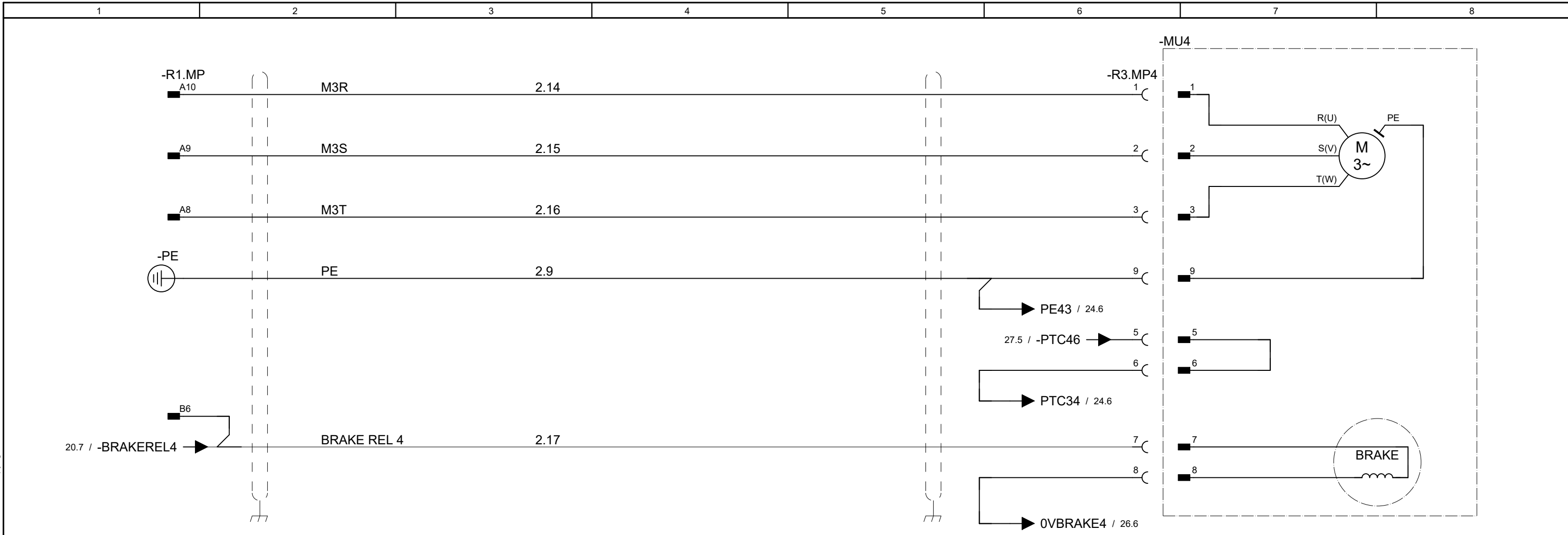

We reserve all rights in this document and in the information contained therein. Reproduction, use or disclosure to third parties without express authority is strictly forbidden. © Copyright 2003 ABB

Latest revision:		ABB	Lab/Office:	Axis 4	Status: 10/14/2020	Plant: =	
Prepared by, date: CNHACHE26	Approved by, date: Chao Xie				Approved	Location: +	Sublocation: +
					Document no. 3HAC021351-003	Rev. Ind 06	Page 25
							Next 26
							Total 17

We reserve all rights in this document and in the information contained therein. Reproduction, use or disclosure to third parties without express authority is strictly forbidden. © Copyright 2003 ABB

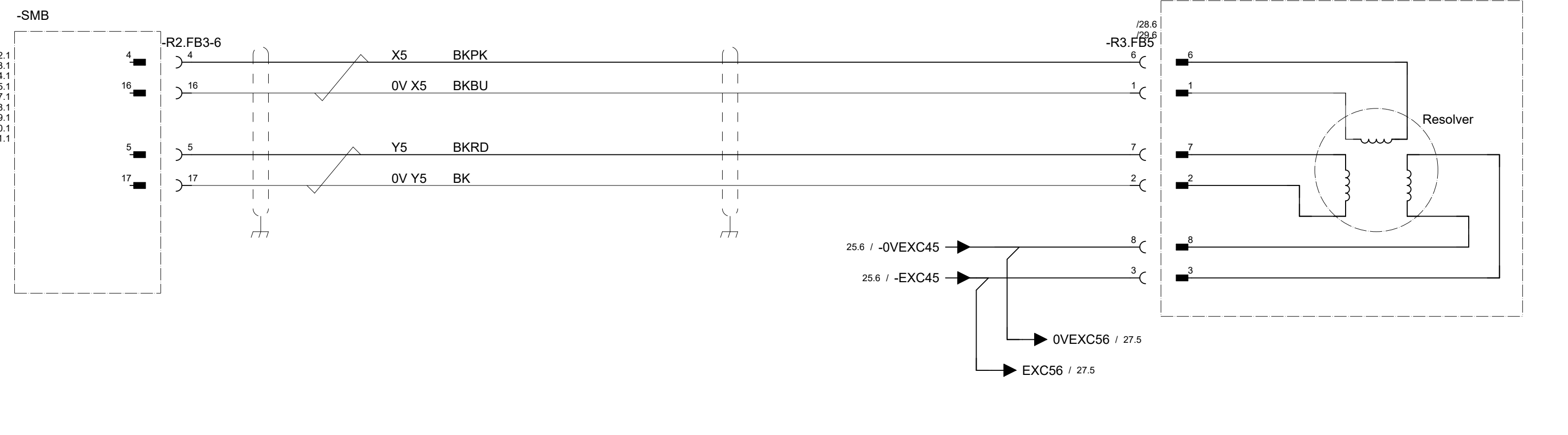
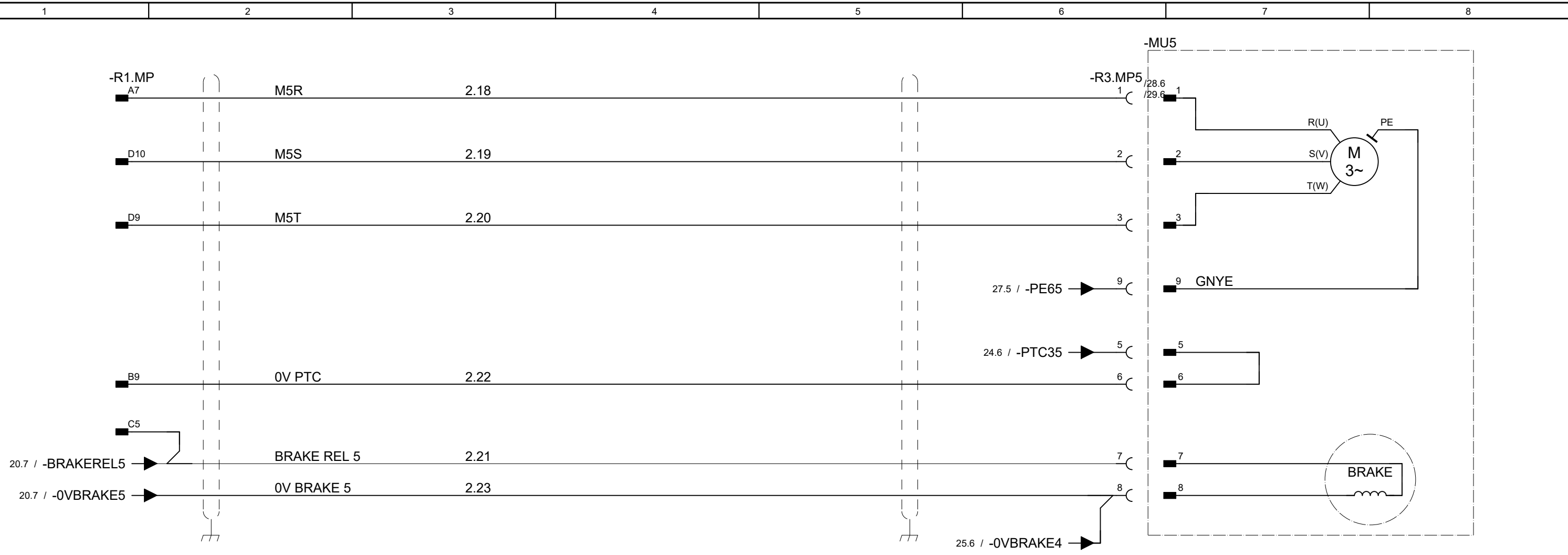

Latest revision:		ABB	Lab/Office:	Axis 5	Status: 10/14/2020	Plant: =
Prepared by, date: CNHACHE26			Approved by, date: Chao Xie		Approved	Location: +
Document no. 3HAC021351-003					Rev. Ind 06	Page 26
						Next 27
						Total 17

We reserve all rights in this document and in the information contained therein. Reproduction, use or disclosure to third parties without express authority is strictly forbidden. © Copyright 2003 ABB

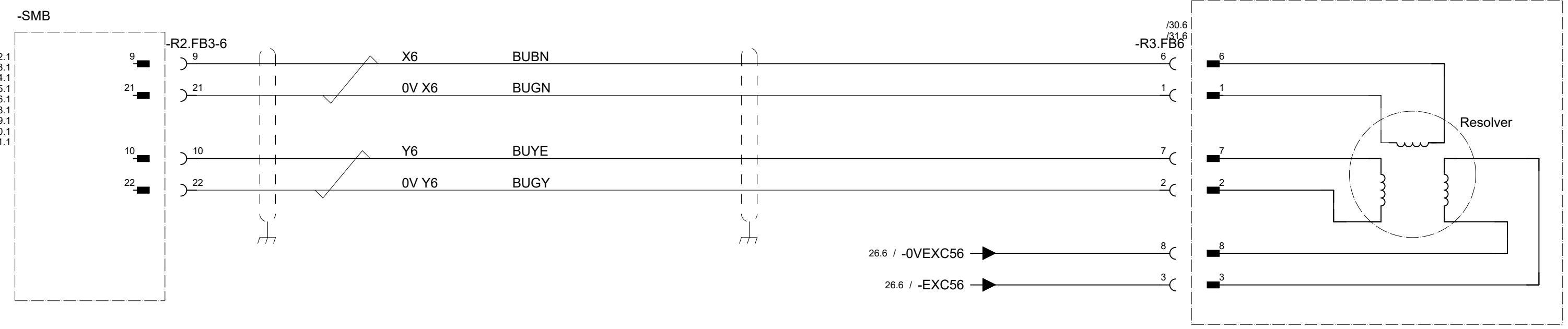
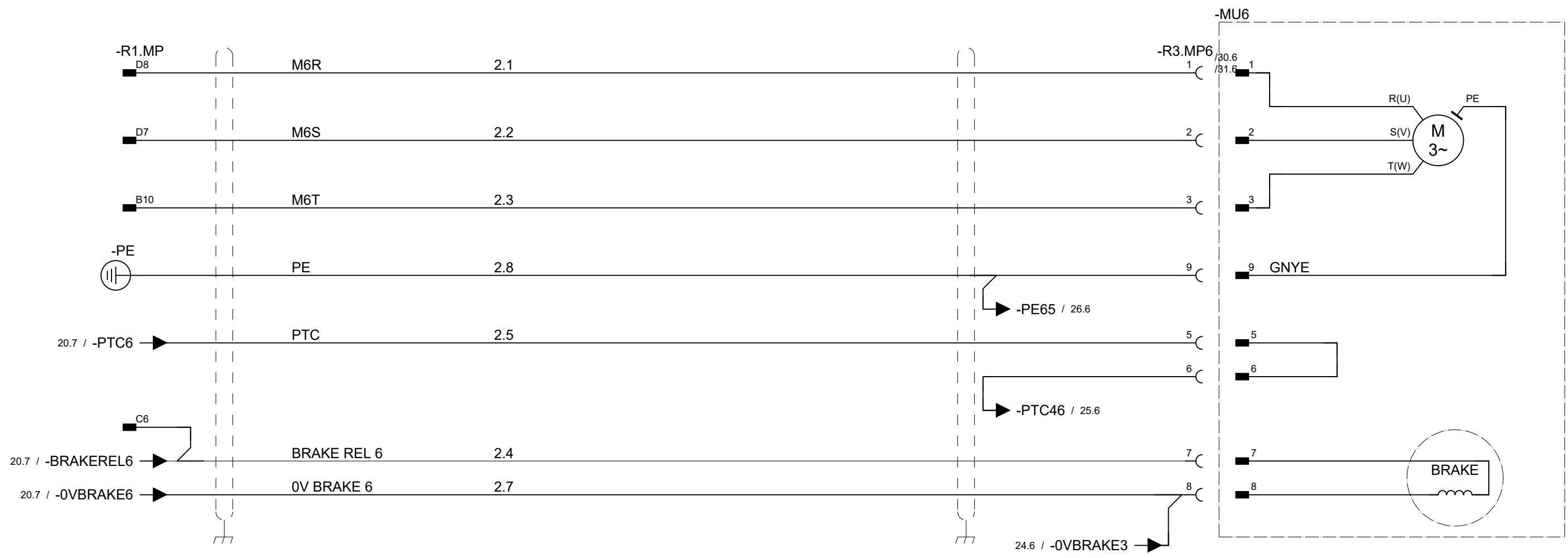

We reserve all rights in this document and in the information contained therein. Reproduction, use or disclosure to third parties without express authority is strictly forbidden. © Copyright 2003 ABB

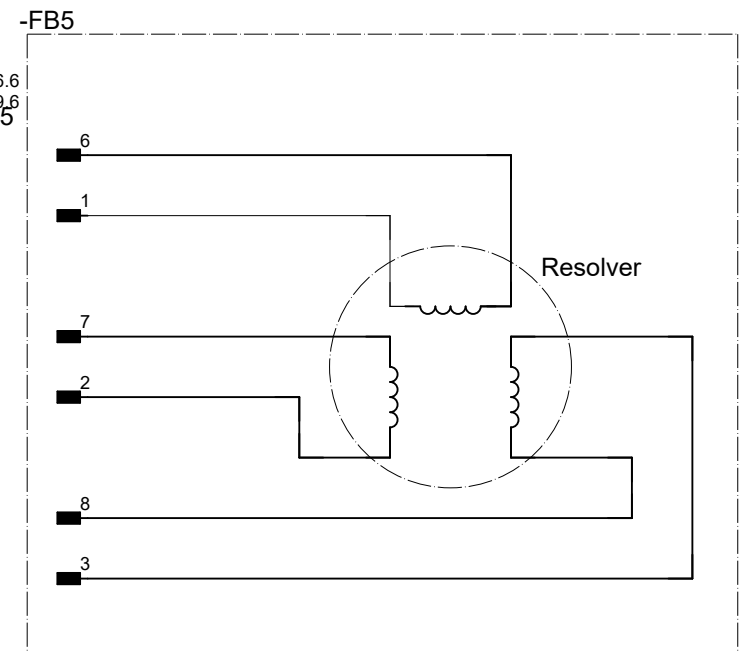
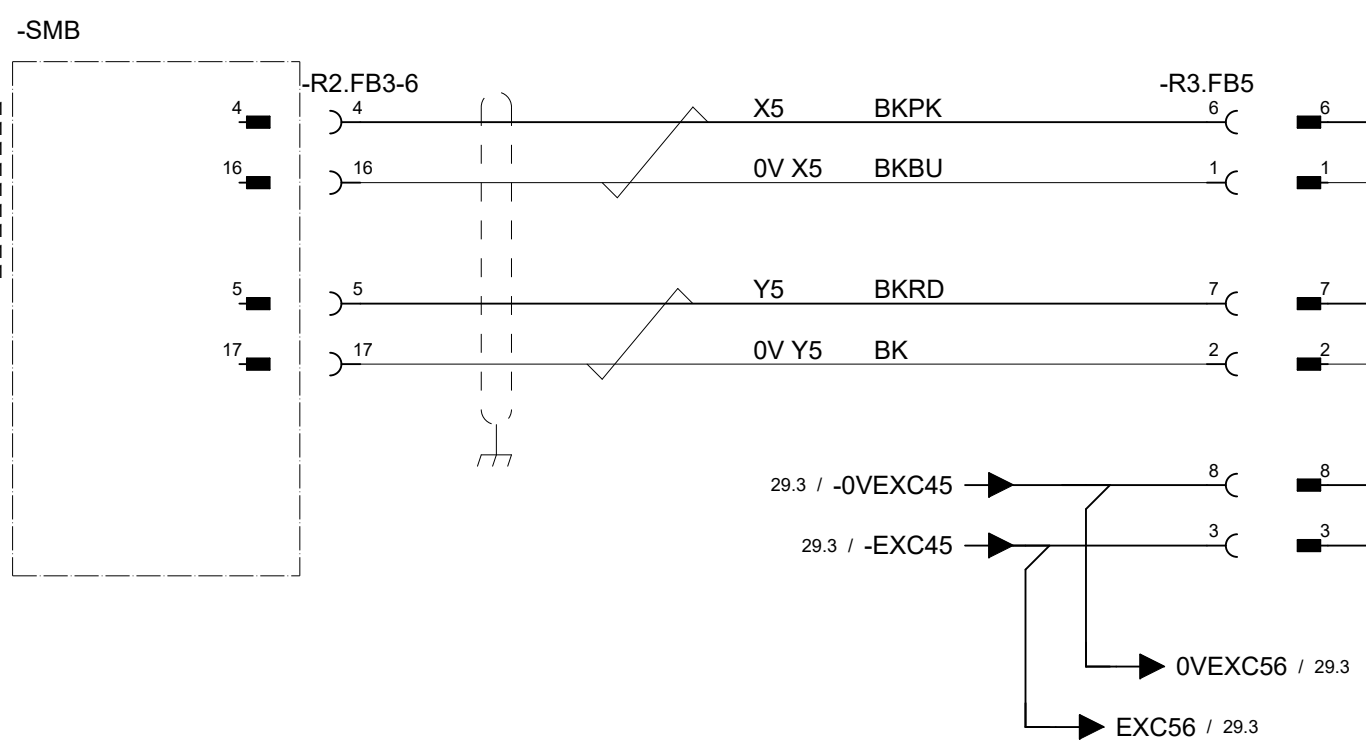
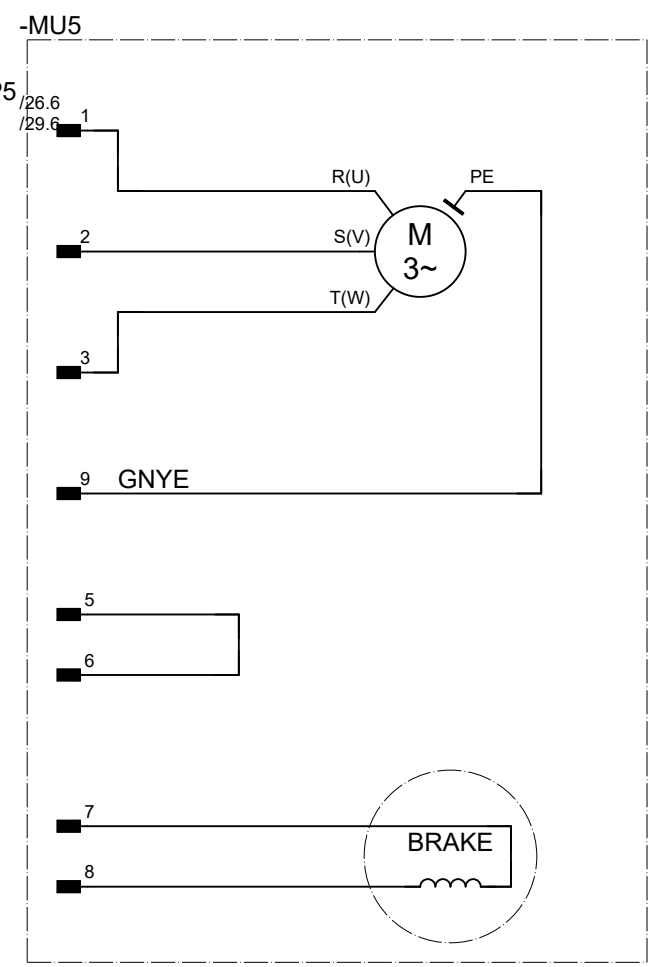
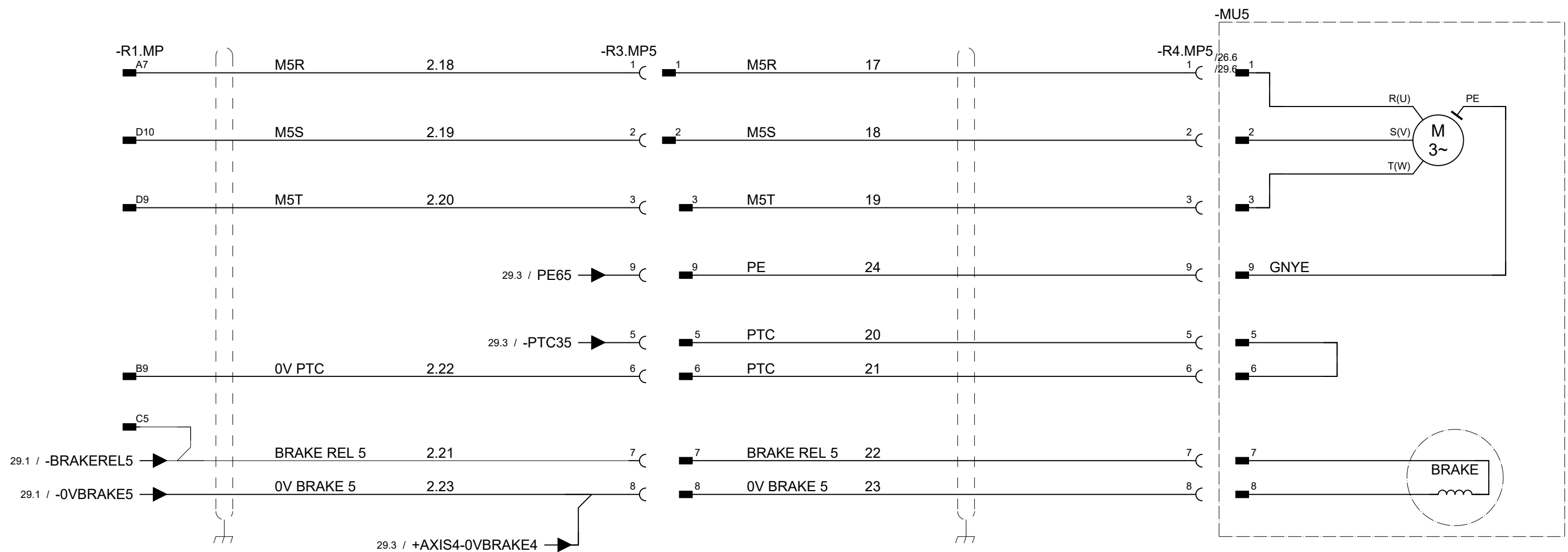

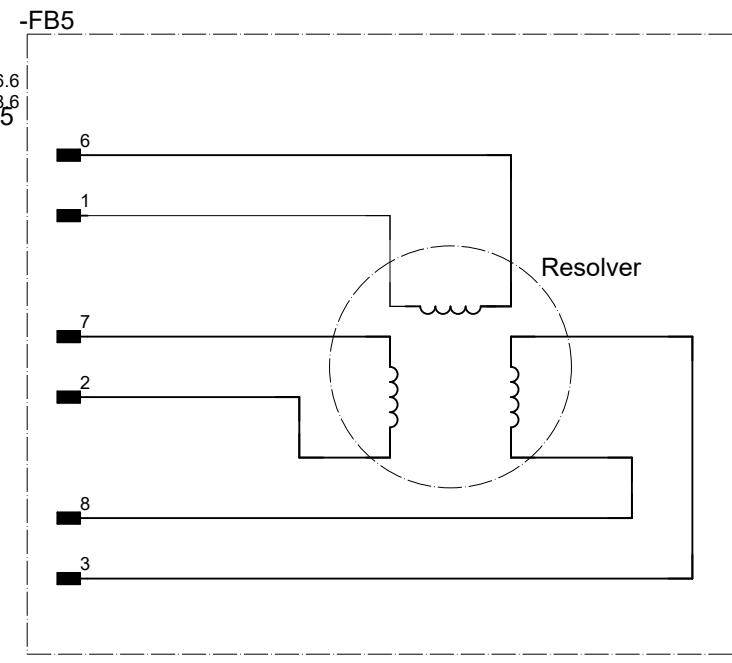
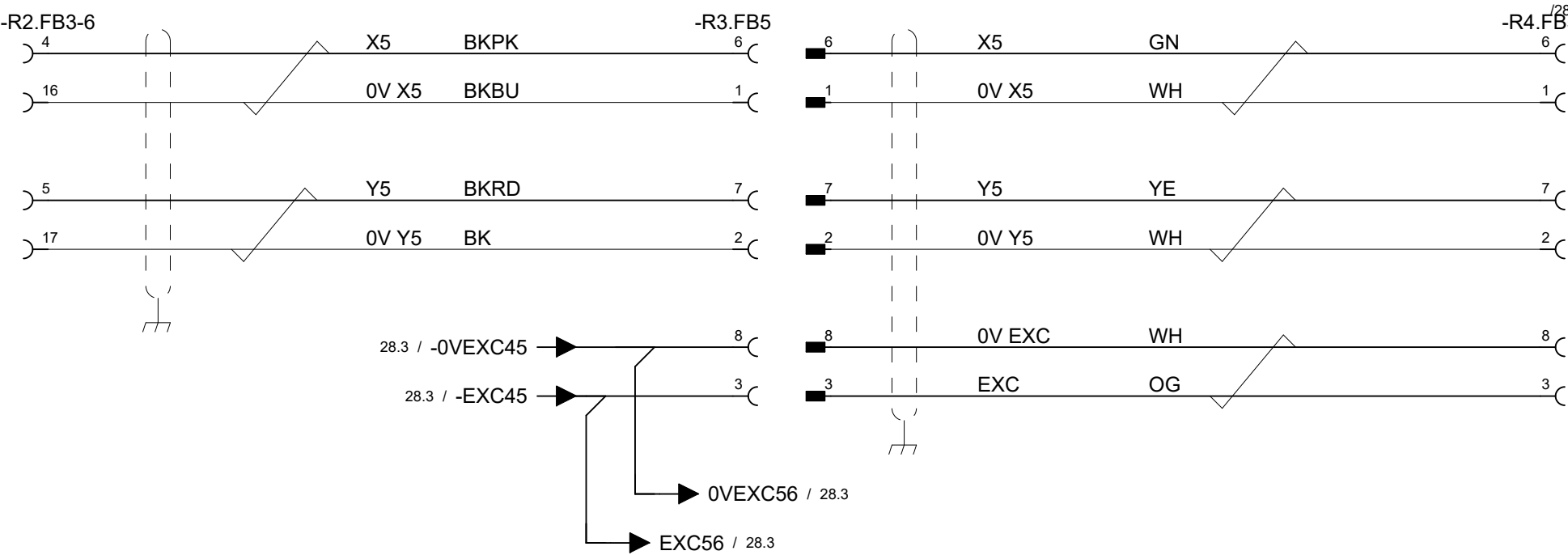
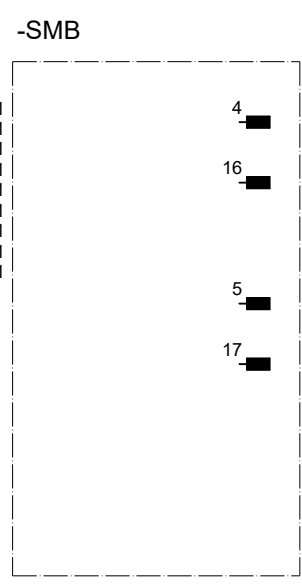
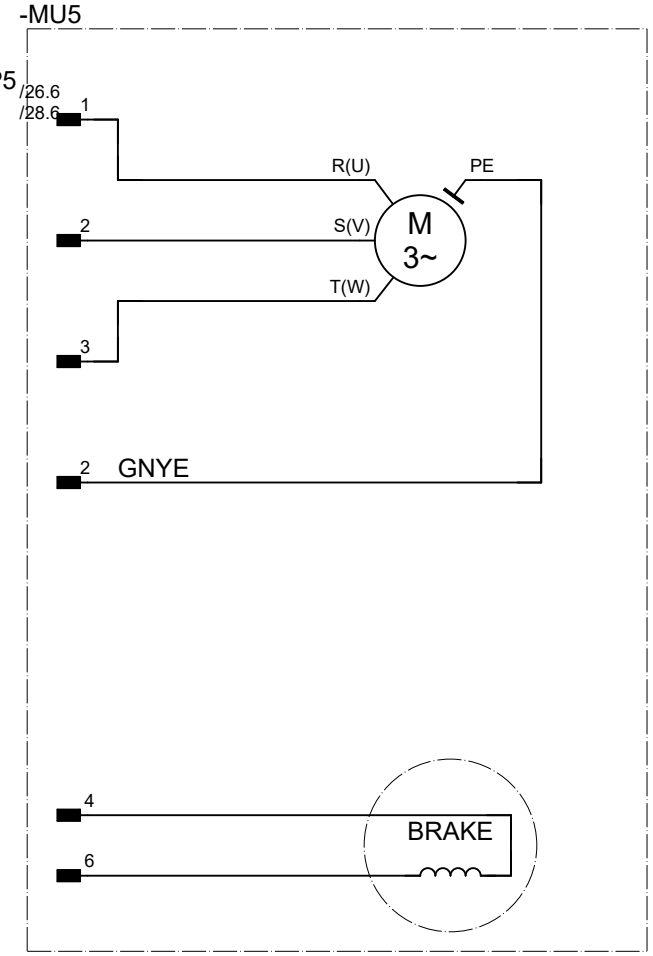
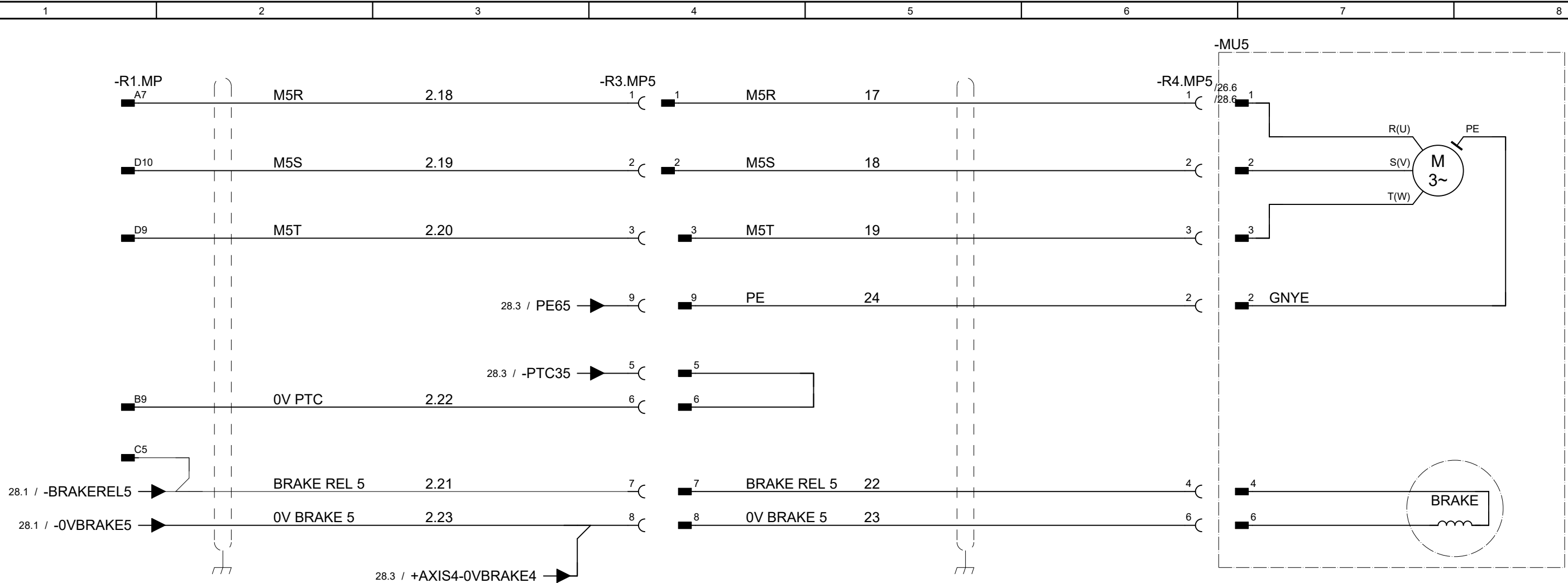

Latest revision:

Prepared by, date: CNHACHE26 Approved by, date: Chao Xie



Axis 5 IRB 1660ID-6/1.55&-4/1.55

Status: 10/14/2020	Plant: =
Approved	Location: +
	Sublocation: +
Document no. 3HAC021351-003	Rev. Ind 06
	Page 29
	Next 30
	Total 17

We reserve all rights in this document and in the information contained therein. Reproduction, use or disclosure to third parties without express authority is strictly forbidden. © Copyright 2003 ABB

We reserve all rights in this document and in the information contained therein. Reproduction, use or disclosure to third parties without express authority is strictly forbidden. © Copyright 2003 ABB

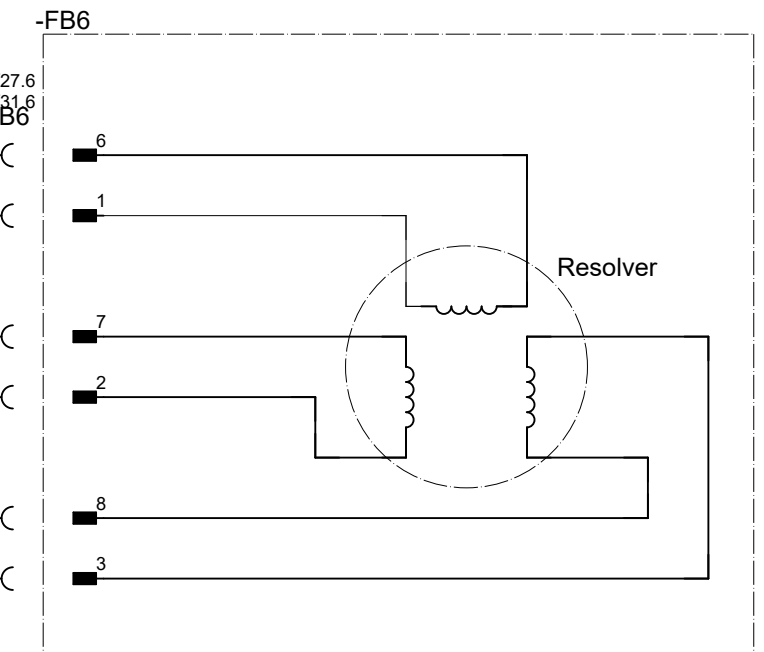
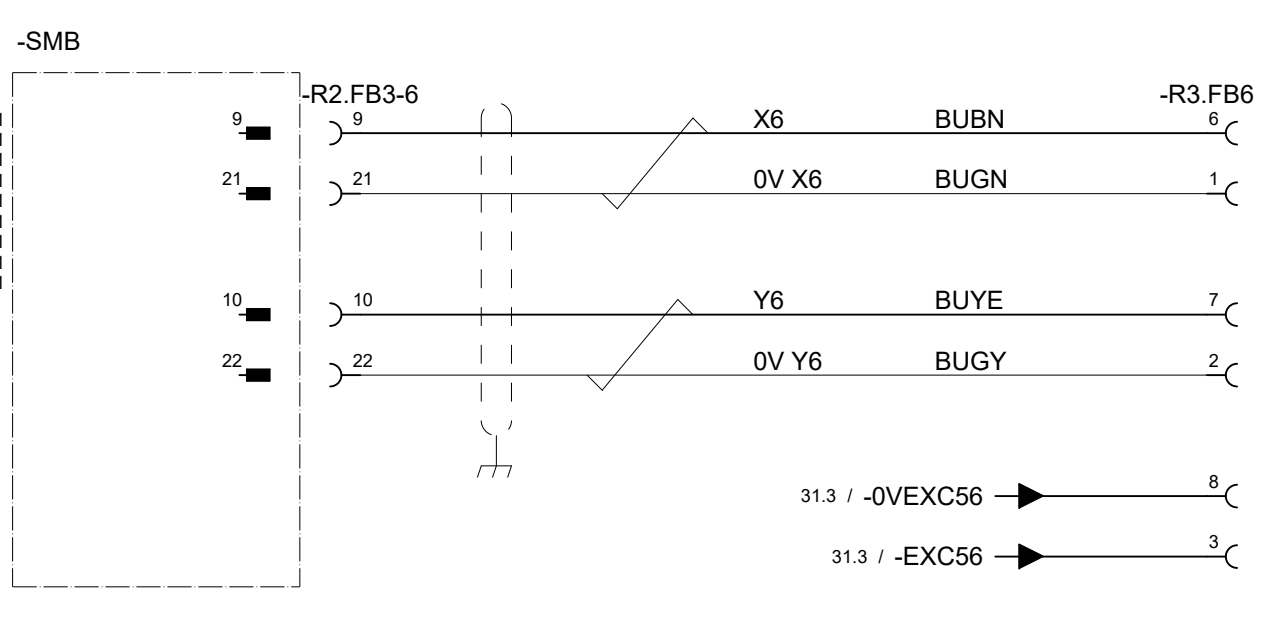
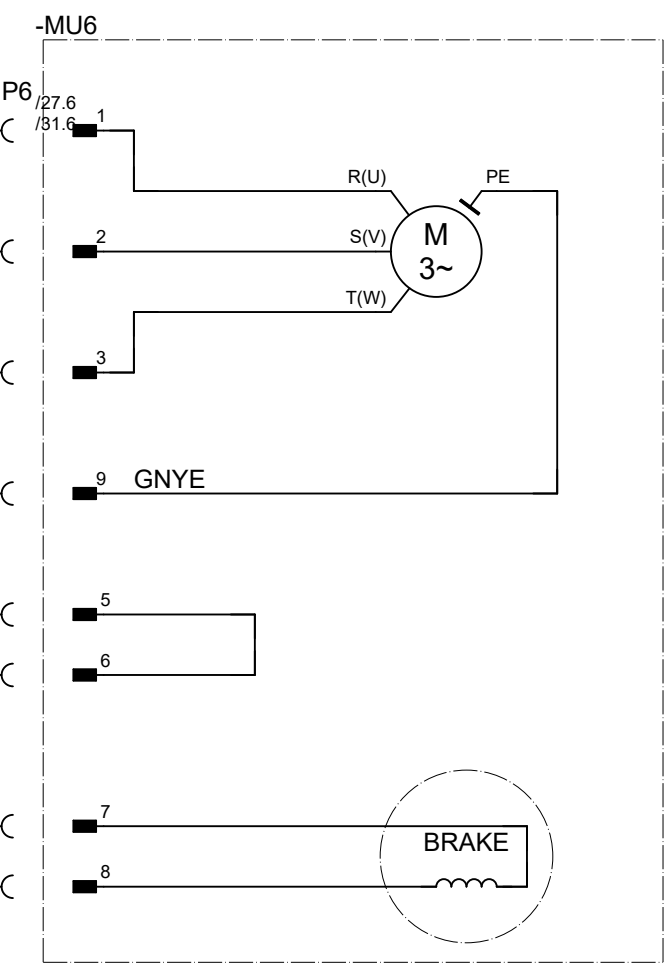
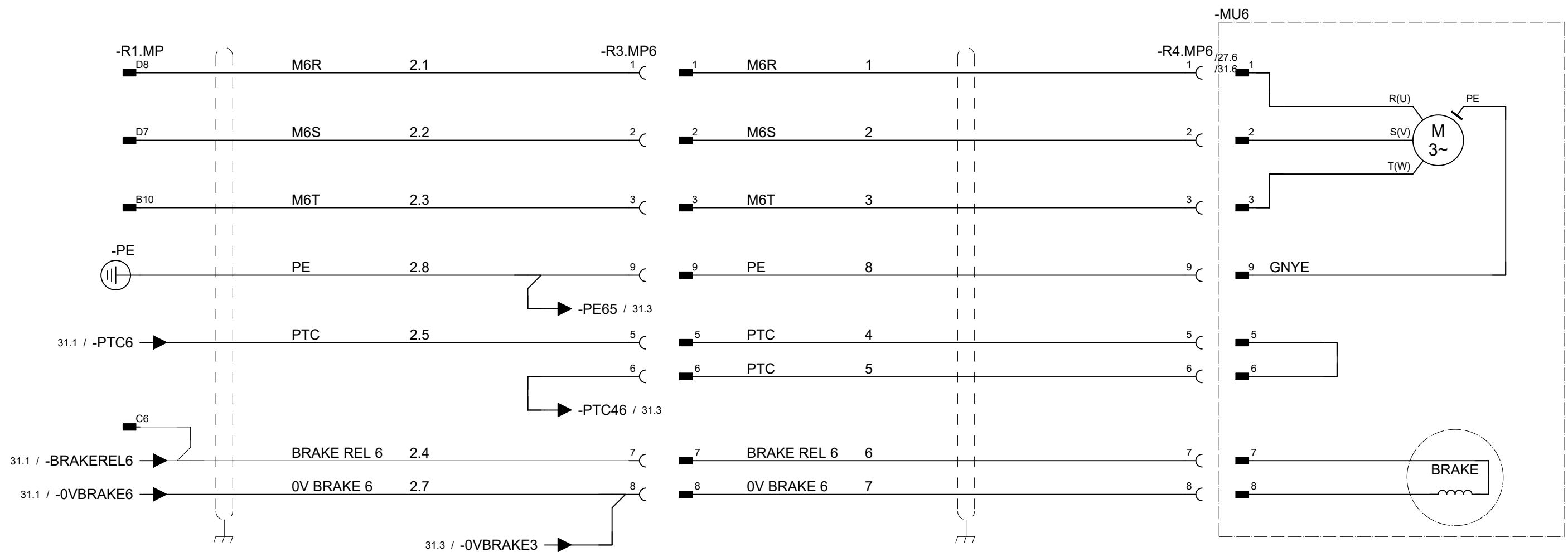

We reserve all rights in this document and in the information contained therein. Reproduction, use or disclosure to third parties without express authority is strictly forbidden. © Copyright 2003 ABB

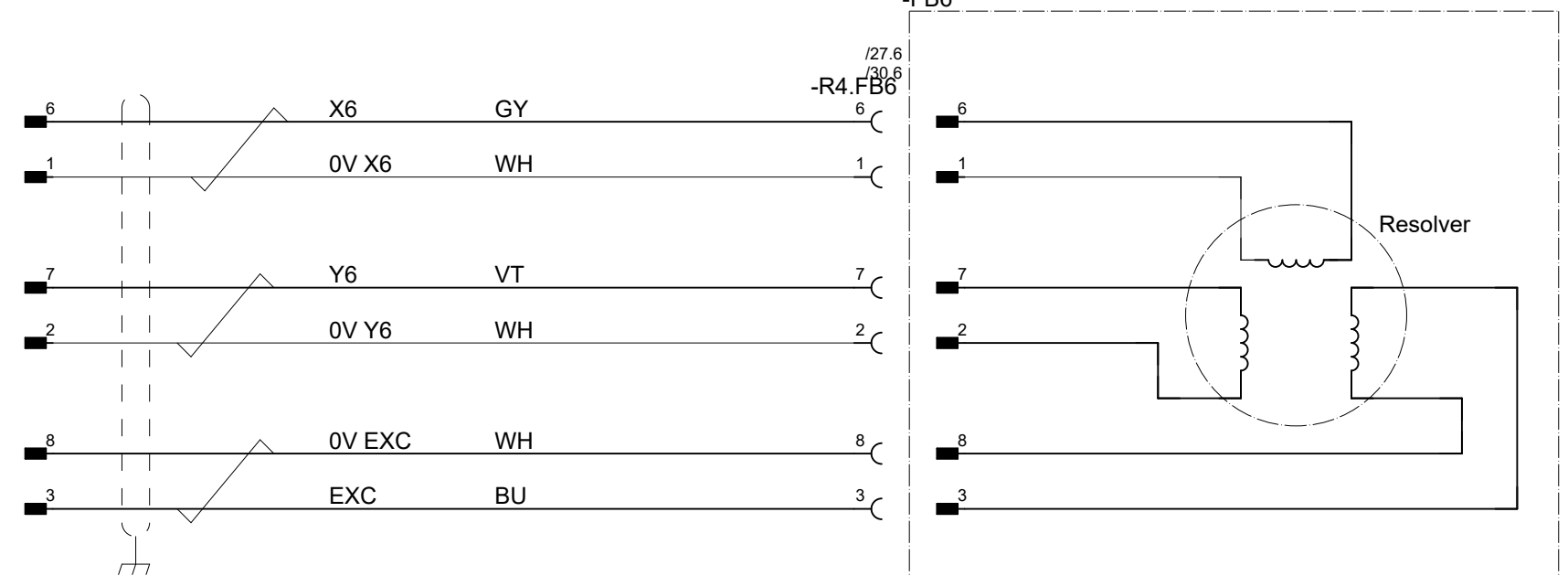
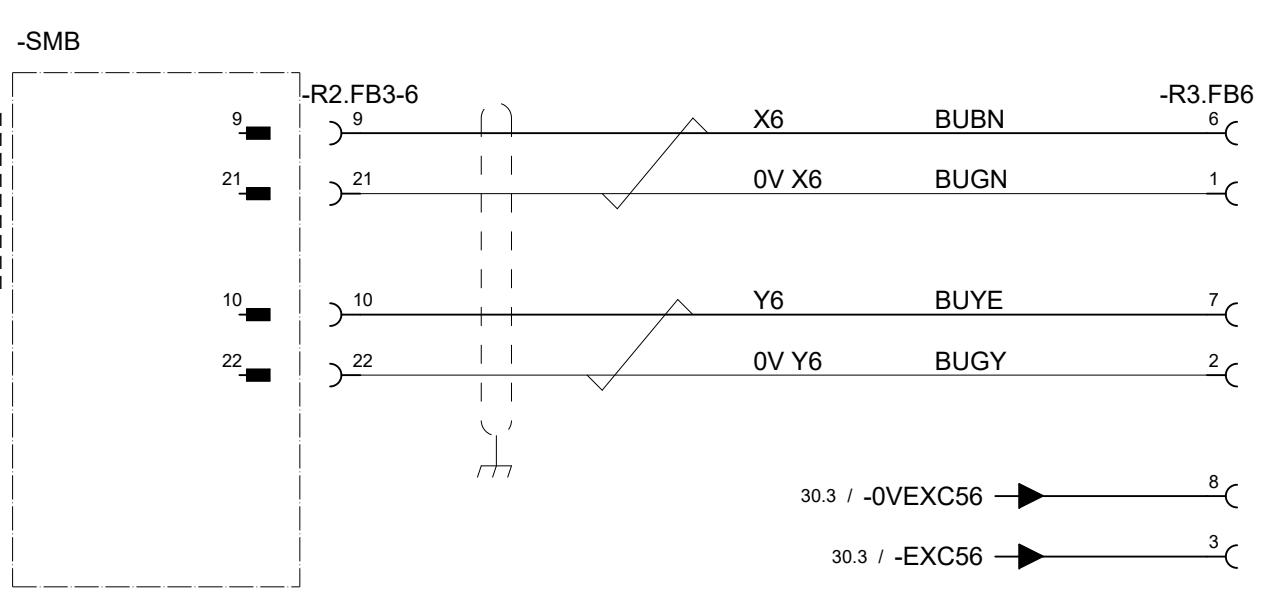
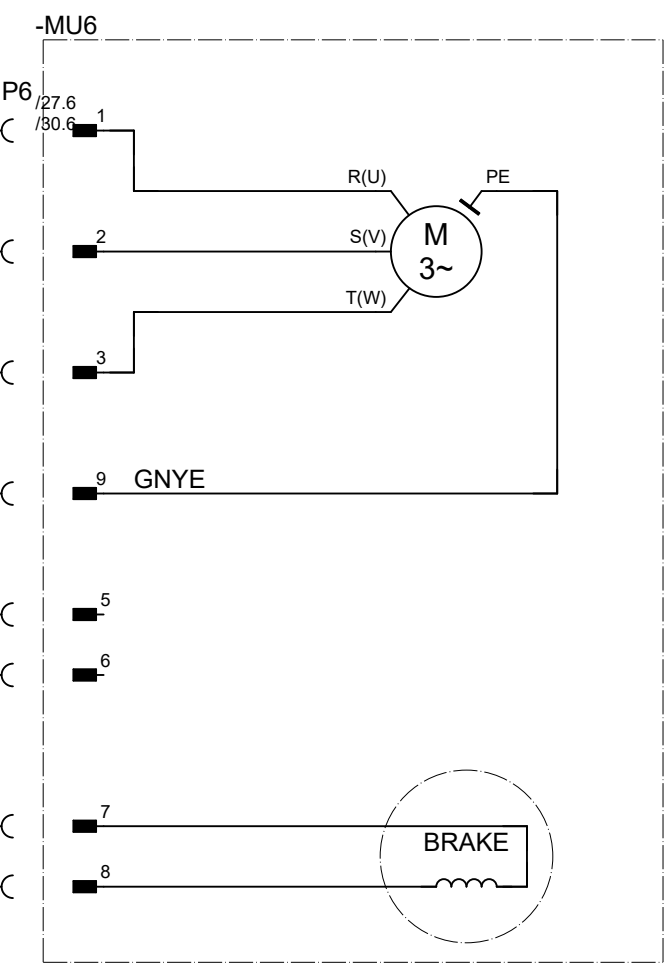
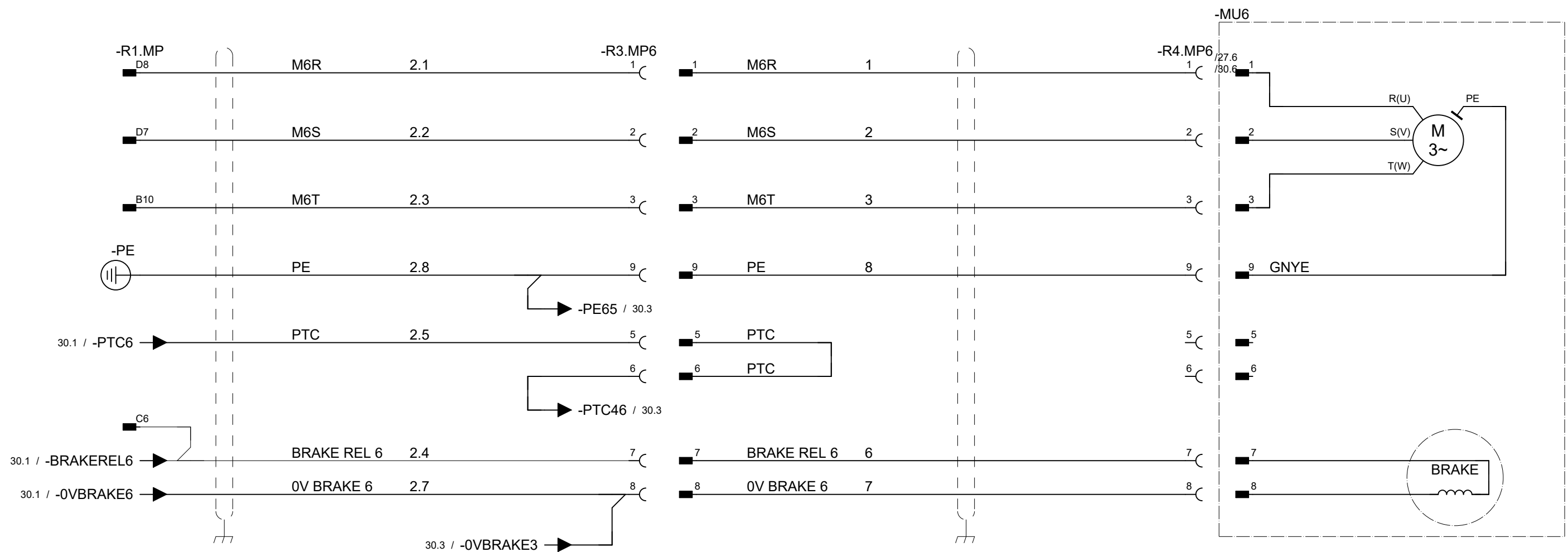

Latest revision:

Prepared by, date: CNHACHE26 Approved by, date: Chao Xie



Axis 6 IRB 1660ID-6/1.55&-4/1.55

Status:	10/14/2020	Plant:	=
Approved		Location:	+
		Sublocation:	+
Document no.	3HAC021351-003	Rev. Ind	06
		Page 31	
		Next 32	
		Total 17	

-R1.CP/CS-

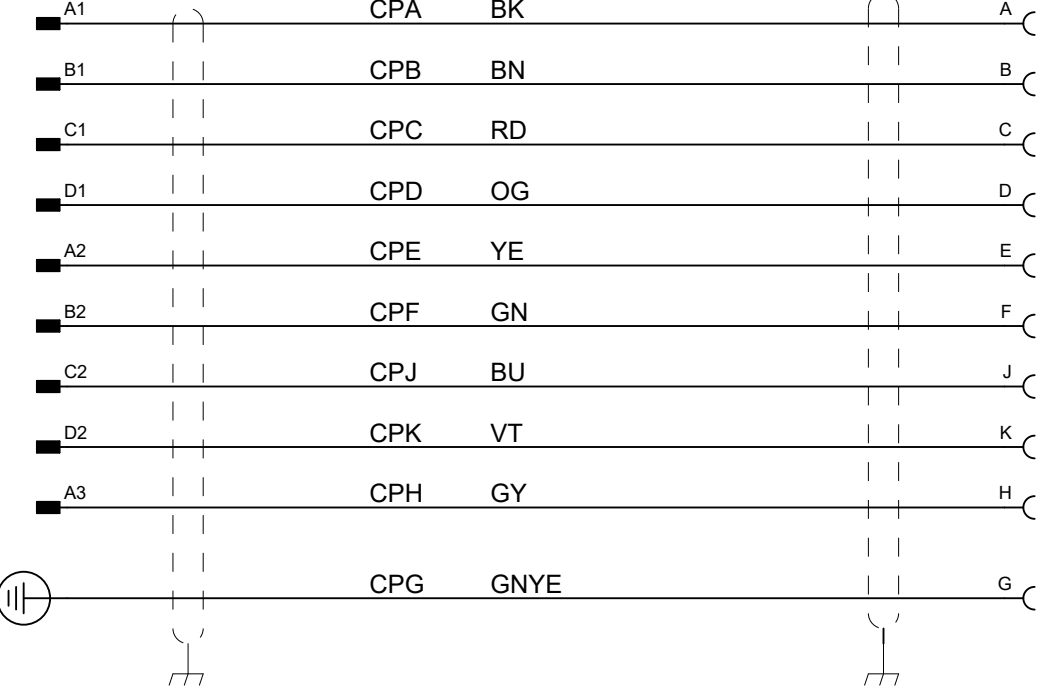

-R2.CP

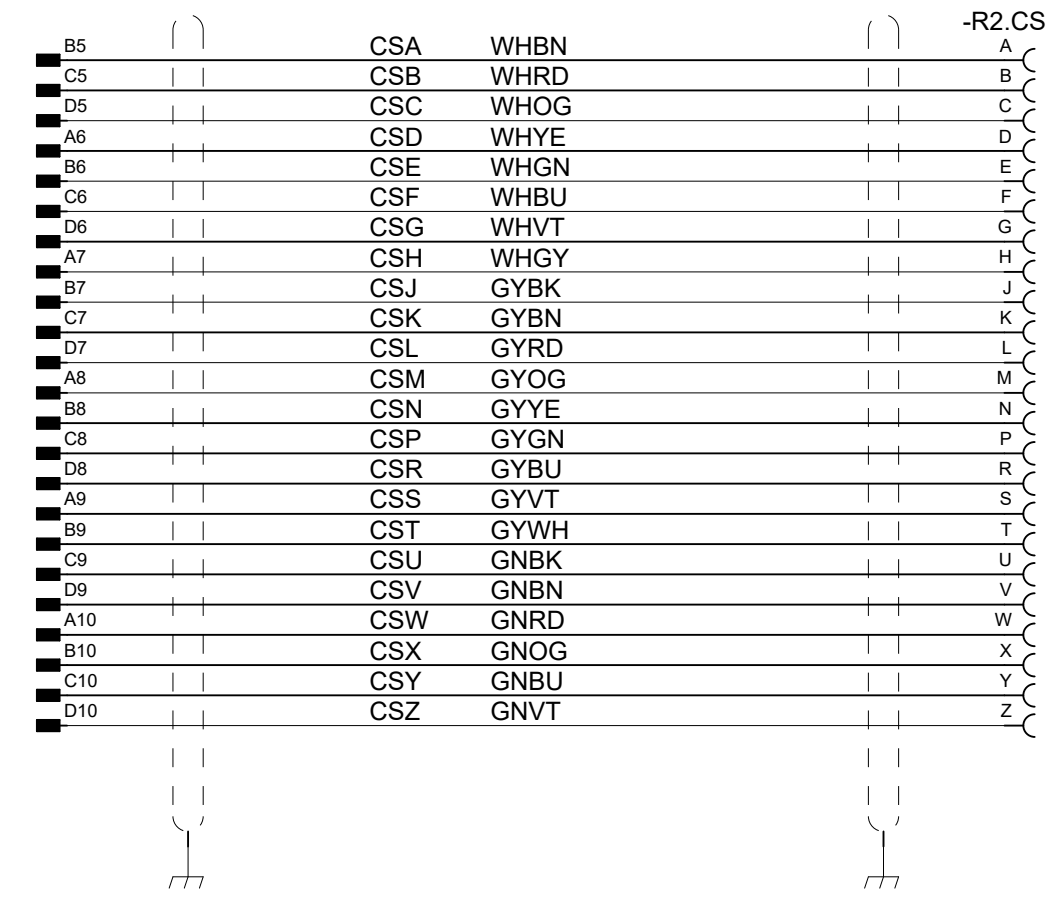

-R2.CS

We reserve all rights in this document and in the information contained therein. Reproduction, use or disclosure to third parties without express authority is strictly forbidden. © Copyright 2003 ABB

Latest revision:

Prepared by, date: CNHACHE26 Approved by, date: Chao Xie



Lab/Office:

Customer Connections

Status: 10/14/2020	Plant: =
Approved	Location: +
	Sublocation: +
Document no. 3HAC021351-003	Rev. Ind 06
	Page 32
	Next 33
	Total 17

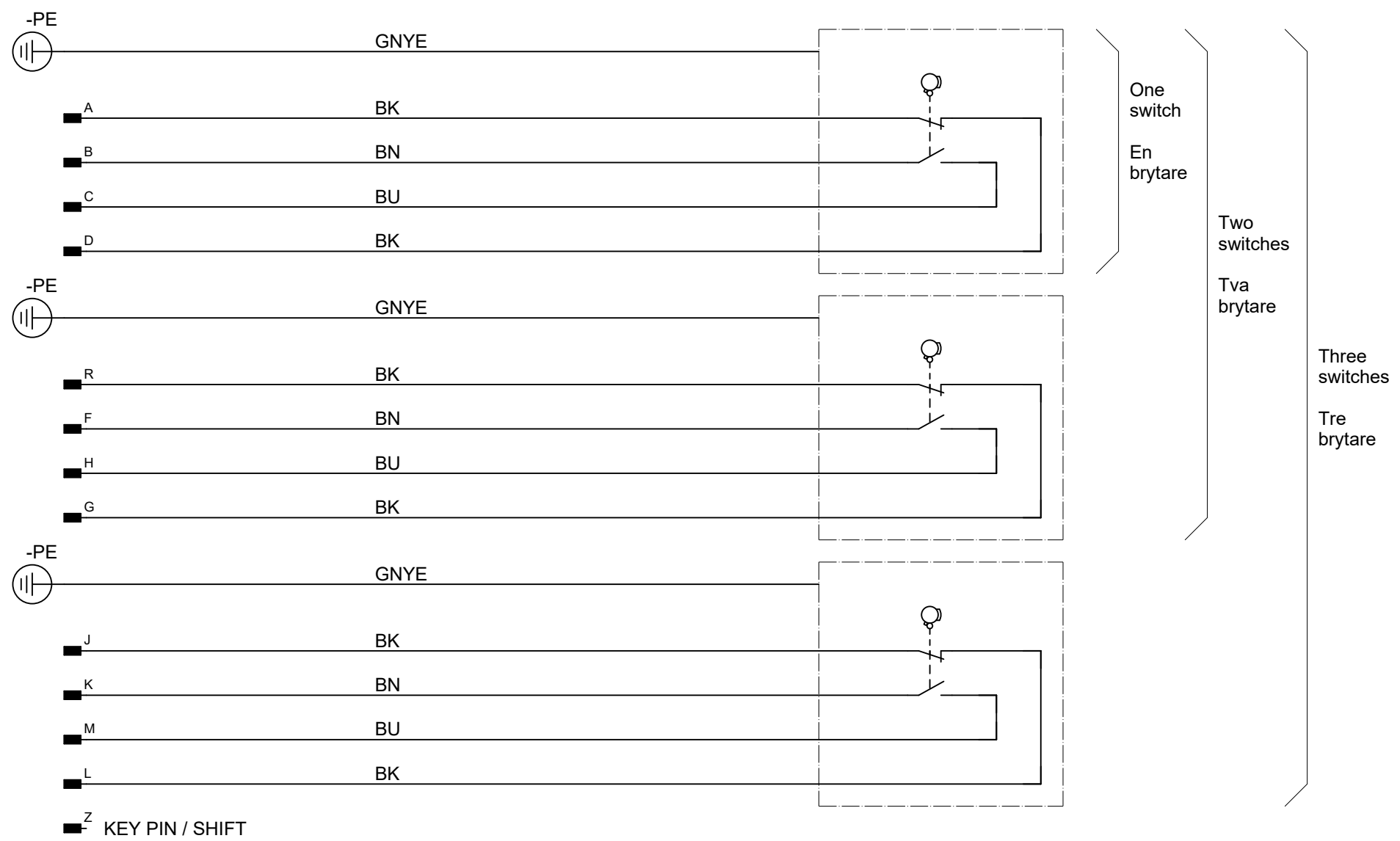

We reserve all rights in this document and in the information contained therein. Reproduction, use or disclosure to third parties without express authority is strictly forbidden. © Copyright 2003 ABB

Latest revision:

Prepared by, date: CNHACHE26 Approved by, date: Chao Xie



Lab/Office:

Position Indicator Axis 1; Option

Status: 10/14/2020	Plant: =
Approved	Location: +
	Sublocation: +
Document no. 3HAC021351-003	Rev. Ind 06
	Page 33
	Next
	Total 17